

# AMR

## BACnet MS/TP Connectivity Made Simple!

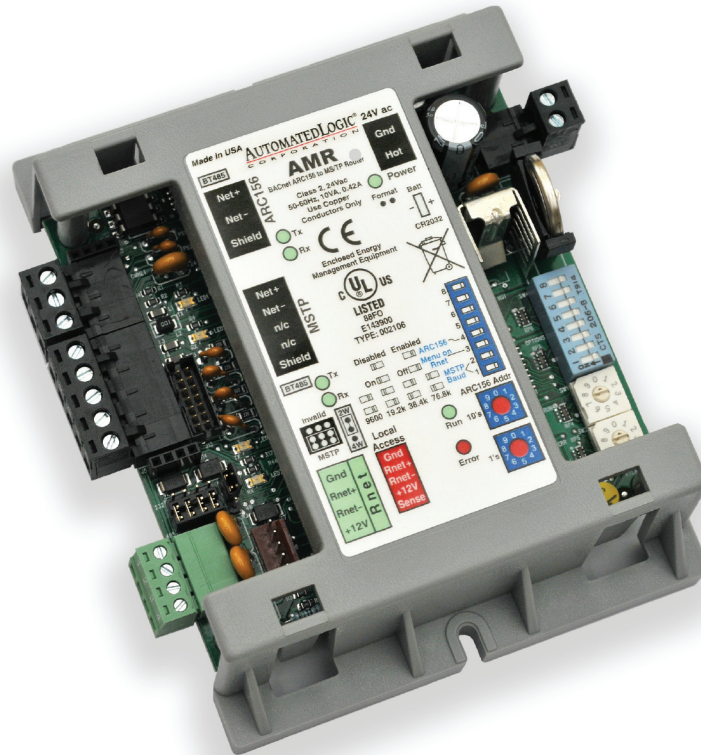

Automated Logic's AMR makes routing between ARC156 to BACnet MS/TP networks easy! The AMR is compact, rugged and cost effective, enabling faster ARC156 BACnet networks to be routed to slower MS/TP devices or networks.

### Key Features and Benefits

- Serves as an economical field router to a single piece of equipment/device using BACnet MS/TP or a network of devices that communicate using BACnet MS/TP. (Note: Recommended maximum is 32 BACnet MS/TP devices.)
- Rotary address switches for setting the AMR's network address.
- Rnet port for local communication and driver download.
- Battery-backed real-time clock + RAM ensures continuous operation during power failures and communications failures.
- Flash memory allows for easy field upgrades over network.
- 16-bit microprocessor combined with ARCNET 156 kbps communications offers ample horsepower and speed for equipment integration requirements.

**AUTOMATEDLOGIC**<sup>®</sup>  
CORPORATION

1150 Roberts Boulevard  
Kennesaw, Georgia 30144  
770/429-3000  
Fax 770/429-3001  
www.automatedlogic.com

CSAMR

# AMR

## Specifications

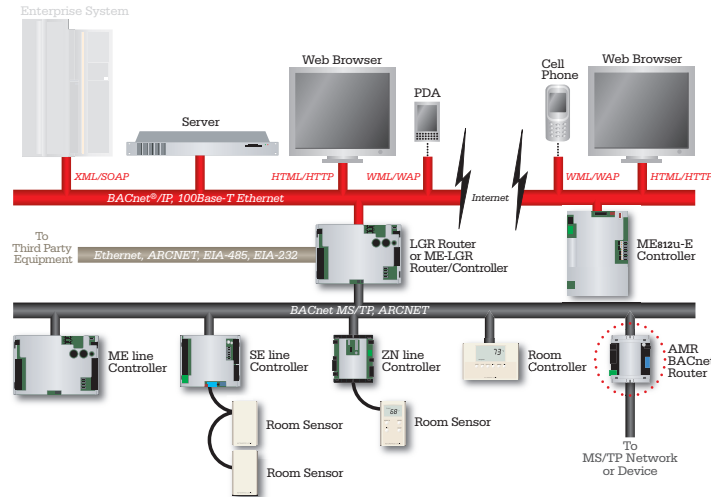

BACnet Support:	Conforms to the Advanced Application Controller (B-AAC) Standard Device Profile as defined in ANSI/ASHRAE Standard 135-2004 (BACnet) Annex L.
Communication:	The following ports are available: <ul style="list-style-type: none"> <li>- ARC156 port for communication with the ARC156 network.</li> <li>- MSTP port for communication with the MS/TP network on EIA-485 (2-wire). The AMR acts as a master device on the MS/TP network.</li> <li>- Local Access port for system start-up and troubleshooting.</li> <li>- Rnet port not used.</li> </ul>
Microprocessor:	High speed 16-bit microprocessor with ARCNET communication co-processor.
Memory:	1 MB non-volatile battery-backed RAM, 4 MB Flash memory, 16-bit memory bus.
Real-time Clock:	Battery-backed real-time clock keeps track of time in event of power failure.
Battery:	10-year Lithium CR2032 battery provides a minimum of 10,000 hours of data retention during power outages.
Status Indicators:	LED's indicate status of communications, running, errors, and power.
Protection:	Incoming power and network connections are protected by non-replaceable internal solid-state polyswitches that reset themselves when the condition that causes a fault returns to normal. The power and network connections are also protected against voltage transient and surge events.
BT485 Connector:	A BT485 is attached to a control module at the beginning and end of a network segment to add bias and to terminate a network segment.
Listings:	UL-916 (PAZX), cUL-916 (PAZX7), FCC Part 15-Subpart B-Class A, CE EN50082-1997.
Environmental Operating Range:	0 to 130°F (-17.8 to 54.4°C), 10–90% relative humidity, non-condensing. NOTE: Control module must be installed within the building.
Power Requirements:	24 Vac ±10%, 50–60 Hz, 10 VA, single Class 2 source only 20 VA or less. 26 Vdc ±10%, 5W.
Physical:	Rugged GE C2950 Cycloplastic.
Weight:	0.4 lbs (0.2 kg).
Dimensions:	4" (10.2cm) width by 5" (12.7cm) height.
Mounting:	5 <sup>9</sup> / <sub>16</sub> " (14.1 cm) between mounting slot centerlines. Recommended panel depth: 1.75" (5.1 cm)

