

ME-LGR line

Powerful Multi-Equipment Controllers and Routers

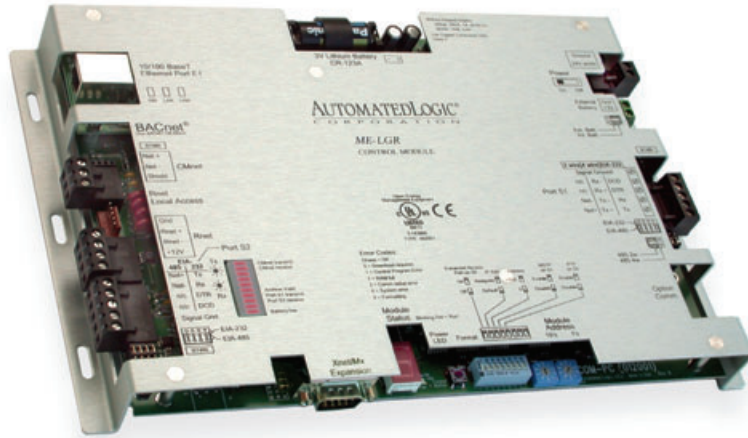

Combining the features of our powerful multi-equipment controller with a high-speed BACnet router, the ME-LGR can do it all. Need 100 Mbps communications to a critical control site? Need to control multiple pieces of equipment at that site? Need to integrate third-party equipment on a proprietary network with your BACnet system? No problem. The ME-LGR can do it all, and it can also serve as a router to controllers on an ARCNET 156 Kbps or MS/TP network.

Key Features and Benefits

- Multi-equipment capabilities support general HV-ac applications including complex central plants.
- 10/100Base-T Fast Ethernet provides high speed communications to controller; ideal for critical control applications.
- 10/100Base-T Fast Ethernet allows modules to serve as a BACnet router between BACnet/IP system backbone and field devices subnetwork.
- Native BACnet communications to field devices over a high-speed ARCNET 156 Kbps or BACnet MS/TP network.
- Protocol translator package allows the ME controllers to serve as a gateway between BACnet and a wide range of open and proprietary networks.
- Controller units include an expansion port for MEx I/O expanders or previous generation MX expanders. Up to six MEx expanders can be mounted in a stack or remotely mounted for scalable control solutions.
- Designed with a high-speed true 32-bit microprocessor with cache memory, Fast Ethernet controller, high performance 32-bit serial communications co-processor, ARCNET communications co-processor and CAN (Control Area Network) co-processor, ME-LGR controllers have the horsepower to serve the most demanding control applications.
- 16 MByte battery-backed SDRAM (32 bit wide), with 12 MBytes available for use, stores application programs, trends and other data when power is lost.
- 8 MByte Flash memory (32 bit wide) for easy field upgrades over the network.
- Battery backed real-time clock provides true standalone capabilities. Control modules recover from power failures providing full continuity of operations, even when communications are disrupted.
- Rnet port supports Automated Logic's line of RS room sensors and BACview⁶ local operator interface, and provides local access to the system. Enhanced local access is also available on EIA-232 port.
- ME line controllers are fully graphically programmable and offer full peer-to-peer communications with other ME line, SE line or ZN line controllers. Graphical programs are universally understood and provide self-documenting control sequences.
- Tough construction delivers superior performance and reliability. Modules are constructed with a rugged aluminum cover which provides optimum electrical protection and noise immunity.

AUTOMATED LOGIC[®]
CORPORATION

1150 Roberts Boulevard
Kennesaw, Georgia 30144
770/429-3000
Fax 770/429-3001
www.automatedlogic.com

ME-LGR line

Specifications

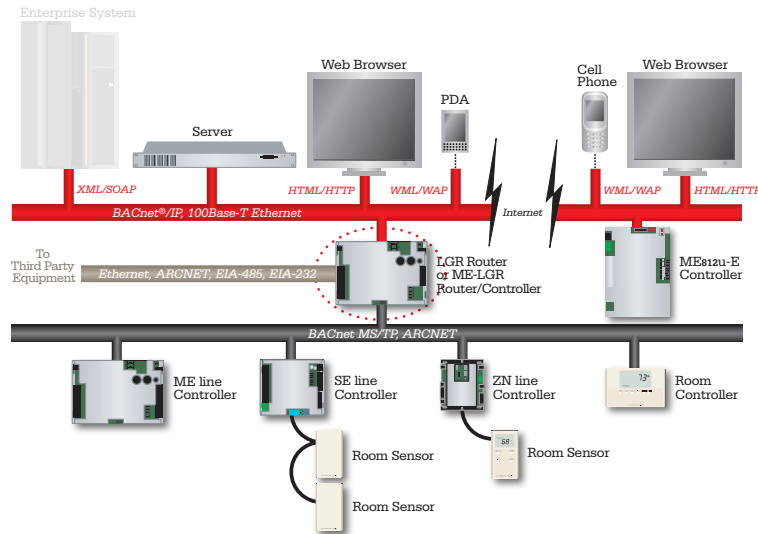

BACnet Support:	Conforms to the BACnet Building Controller (B-BC) Standard Device as defined in BACnet 135-2001 Annex L.
Communication:	The following ports are available on the LGR routers: Ethernet port* (10/100Mbps) for BACnet over Ethernet or BACnet/IP communications. EIA-485 port for ARCNET 156 Kbps or BACnet MS/TP (9600 baud to 76.8 Kbps). EIA-232/485*configurable port for BACnet PTP. Rnet port for RS room sensors and local BACview ⁶ operator displays. Xnet (500Kbps) port for MEX I/O expansion modules. Local access port. <i>*Third-Party integration drivers available through Ethernet and (1) EIA-232/485 configurable port.</i>
Expansion:	Up to 192 points can be added using six MEX or MX expansion modules. MEX expansion modules can be mounted up to 100 feet away from the controller.
Microprocessor:	32-bit Motorola Power PC microprocessor with cache memory, Fast Ethernet controller, high performance 32-bit communication co-processor, ARCNET communication co-processor and I/O expansion CAN co-processor.
Memory:	16 MByte non-volatile battery-backed SDRAM (with 12 MBytes available for use), 8 MByte Flash memory, 32-bit memory bus. (Battery shelf life is 10 years with 720 hours of continuous operation.)
Real-time Clock:	Battery-backed real-time clock.
Status Indicators:	LED status indicators for EIA-232/485 communication, Ethernet port communication, and low battery status. Seven segment status display for running, error, and power status.
Module Addressing:	Rotary dip switches for intuitive network addressing of modules.
Protection:	Built-in surge and transient protection circuitry for power and communications.
Listed by:	UL916 (Canadian Std C22.2 No. 205-M1983), CE, FCC Part 15 - Subpart B - Class A.
Environmental Operating Range:	-20°F to 140°F (-29°C to 60°C); 10 to 90% relative humidity, non-condensing. NOTE: Control modules should be installed within the building.
Power Requirements:	24 V-ac ± 10%, 50 to 60Hz, 24 VA, or 26 V-dc ± 10%, 10W. NOTE: Power consumption will increase when BACview or other accessories are attached.
Physical:	Rugged aluminum cover. Removable screw terminal blocks.
Weight:	1.4 lb. (45.5 kg)

Dimensions:

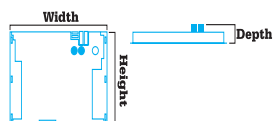

Overall

Width: 11-5/16" (287mm)
Height: 7-1/2" (190mm)
Depth: 2-3/4" (70mm) min. panel depth

Mounting

Width: 10-13/16" (275mm)
Height: 5" (127mm)

