

ZN551

Zone Controller



Automated Logic's ZN551 provides unprecedented power and flexibility through fully programmable networked controllers. The ZN551 controllers connect to the Building Automation System (BAS) network using BACnet over ARCNET 156 Kbps or MS/TP. The ZN551 supports a line of RS room sensors using Rnet port.

Key Features and Benefits

- Powerful zone controller for VAV, heat pump, unit ventilator and other packaged HV-ac applications.
- Native BACnet communications to field devices over a high speed ARCNET 156 Kbps or BACnet MS/TP network.
- Uses a high speed 16-bit microprocessor with 1 MByte Flash memory and 512 KByte of RAM for unparalleled programmability. Firmware upgrades can be downloaded remotely – no chip replacement necessary.
- The ZN551 is part of a full line of ZN controllers which include a variety of Universal Inputs, Binary Outputs and 0-10V-dc Analog Outputs. Other ZN models with built-in flow sensors and/or integral damper actuators are available as well as optional single/dual air flow sensors for pressure independent VAV applications.
- Rnet port supports Automated Logic's line of RS room sensors and provides local access to the system.
- The ZN551 controller is fully graphically programmable and offers full peer-to-peer communications with other ZN line, ME line or SE line controllers. Graphical programs are universally understood and provide self-documenting control sequences.
- An extensive library of pre-engineered control routines provides proven solutions for most zone control applications. Custom programs can be easily written in EIKON®-LogicBuilder, ALC's legendary graphic programming language.
- Compact and rugged plastic enclosure for easy mounting.

AUTOMATED LOGIC[®]
CORPORATION

1150 Roberts Boulevard
Kennesaw, Georgia 30144
770/429-3000
Fax 770/429-3001
www.automatedlogic.com

CSZN551rev9

ZN551

Specifications

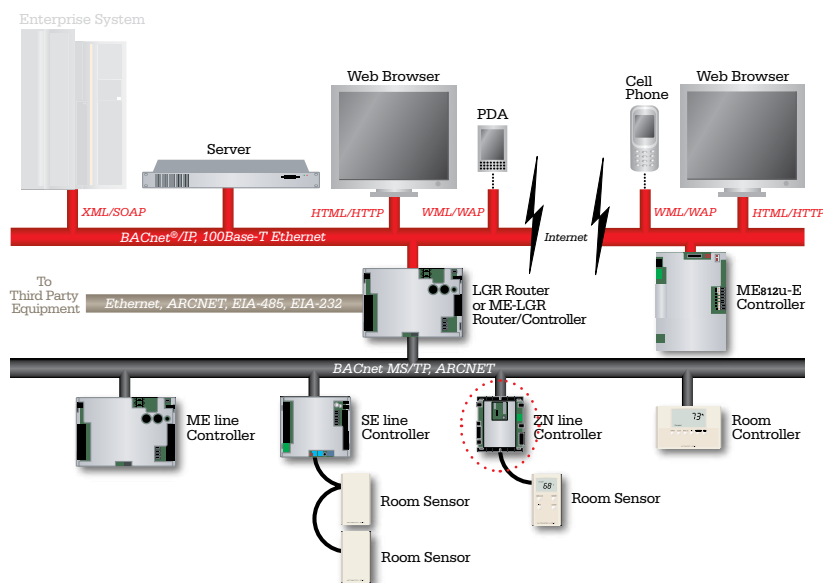

BIBB Support:	Supports BACnet Interoperability Building Blocks (BIBBs) from the following groups: Data Sharing, and Device and Network Management.
Communication:	The following ports are available on the ZN551 module: EIA-485 port for ARCNET 156 Kbps or MS/TP (9600 bps – 76.8 Kbps). Local access port for system start-up and troubleshooting. Rnet port for RS room sensors – the Rnet port supports up to four RS sensors and one RS Pro sensor for averaging or high/low select control. NOTE: Local operator interface (BACview®) is not supported. LogiStat port for LogiStat room sensors. Two Analog Inputs are used by the LogiStat port. NOTE: The LogiStat Pro is not supported on the ZN line (use RS Pro on the Rnet port instead).
Digital Outputs:	Five digital outputs, relay contact rated at 1A max @ 24V-ac, configured normally open.
Universal Inputs:	Five inputs with 10 bit A/D resolution. Two inputs are configurable for dry contact, type 2 thermistors, or 0 - 5 V-dc. Inputs 4 and 5 are taken when a LogiStat sensor is connected – these inputs are available if RS sensors are used.
Analog Outputs:	One analog output, 0-10V-dc with 8-bit resolution.
Microprocessor:	High speed 16-bit microprocessor with ARCNET communication co-processor.
Memory:	512 KByte non-volatile battery-backed RAM, 1 MByte Flash memory, 16-bit memory bus. (Shelf life of the battery is 10 years with 10,000 hours of continuous operation.)
Status Indicators:	LED status indicators for EIA-485 communication, running, error, power and all digital outputs.
Module Addressing:	Rotary dip switches for intuitive network addressing of modules.
Protection:	Built in surge and transient protection circuitry for power and communications.
Listed by:	UL916 (Canadian Std C22.2 No. 205-M1983), CE, FCC Part 15 – Subpart B – Class A
Environmental Operating Range:	0°F to 130°F (-17.8°C to 54.4°C); 10 -90% relative humidity, non-condensing. NOTE: Control modules should be installed within the building.
Power Requirements:	24V-ac ± 10%, 26V-dc (25 V min, 30 V max), 50-60Hz, 15VA
Physical:	Rugged GE C2950 Cylcoloy plastic.
Weight:	0.6 lb. (0.27 kg)

Dimensions:

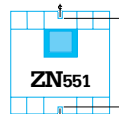

Mounting hole spacing 5-9/16".

Overall

Width: 5-1/16" (129mm)
Height: 5-11/16" (144mm)
Depth: 1-1/2" (38mm) min. panel depth

Mounting*

Two mounting holes center line as at left with 5-9/16" (141mm) spacing (height).

*For indoor use only.

Automated Logic Corporation . 1150 Roberts Boulevard . Kennesaw, Georgia 30144 . 770/429-3000 . Fax 770/429-3001 . www.automatedlogic.com

© 2011, Automated Logic Corporation. Automated Logic, the Automated Logic logo and WebCTRL are registered trademarks of Automated Logic Corporation. BACnet is a registered trademark of ASHRAE. All other trademarks are the property of their respective owners. Specifications are subject to change without prior notice.

CSZN551rev9

